

Use & Care Guide
Manual de Uso y Cuidado
English / Español



Models, Modelos: 407.52301

Kenmore® Dehumidifier Deshumidificador

Sears Brands Management Corporation
Hoffman Estates, IL 60179 U.S.A.

www.sears.com
www.kenmore.com



TABLE OF CONTENTS

| | | | |
|-------------------------------|-----|----------------------------------|------------|
| Package Contents | 2 | Water Disposing Options | 9 |
| Warranty | 2 | Care and Maintenance | 10 |
| Safety Instructions | 3 | Troubleshooting | 11,12 |
| Electrical Requirements | 4 | Product Specification..... | 13 |
| Installation | 5-7 | Master Protection Agreement..... | 14 |
| Key Features | 7 | Spanish Section..... | 15 |
| Control Panel | 8 | Sears Service | Back Cover |

PACKAGE CONTENTS

- Kenmore Dehumidifier
- 4 Casters
- Use and Care Guide

WARRANTY

Kenmore Limited Warranty

When installed, operated and maintained according to all supplied instructions, if this appliance fails due to a defect in material and workmanship within one year from the date of purchase, call 1-800-4-MY-HOME® to arrange for free repair.

If this appliance is ever used for other than private family purposes, this warranty applies for only 90 days from the date of purchase.

This warranty covers only defects in material and workmanship. Warranty coverage does NOT include:

1. Expendable items that can wear out from normal use, including but not limited to filters, belts, light bulbs, and bags.
2. A service technician to instruct the user in correct product installation, operation or maintenance.
3. A service technician to clean or maintain this product.
4. Damage to or failure of this product if it is not installed, operated or maintained according to the all instructions supplied with the product.
5. Damage to or failure of this product resulting from accident, abuse, misuse or use for other than its intended purpose.
6. Damage to or failure of this product caused by the use of detergents, cleaners, chemicals or utensils other than those recommended in all instructions supplied with the product.
7. Damage to or failure of parts or systems resulting from unauthorized modifications made to this product.

Disclaimer of implied warranties; limitation of remedies

Customer's sole and exclusive remedy under this limited warranty shall be product repair as provided herein. Implied warranties, including warranties of merchantability or fitness for a particular purpose, are limited to one year or the shortest period allowed by law. Sears shall not be liable for incidental or consequential damages. Some states and provinces do not allow the exclusion or limitation of incidental or consequential damages, or limitation on the duration of implied warranties of merchantability or fitness, so these exclusions or limitations may not apply to you.

This warranty applies only while this appliance is used in the United States.

This warranty gives you specific legal rights, and you may also have other rights which vary from state to state.

Sears Brands Management Corporation, Hoffman Estates, IL 60179

SAFETY INSTRUCTIONS

IMPORTANT CAUTIONS FOR USING YOUR DEHUMIDIFIER.



To reduce the risk of fire, electrical shock, injury, or damage to the dehumidifiers, these safety precautions must be followed:

Safety

- Do not place the power cord near a heater.
- Do not use an electrical outlet near flammable or combustible materials such as gasoline, propane, paint thinners, etc.
- Do not disassemble or modify dehumidifier parts or components. It may cause electric shock and failure.
- Plug in the power cord properly.
- Do not turn the unit on and off by inserting or pulling out the power plug.
- Do not damage the power cord or use an unspecified power cord.
- Do not modify power cord length.
- Do not share the outlet with another appliance.
- Always plug into a grounded outlet. Not grounding unit may cause electrical shock.
- Unplug the unit if it emits strange sounds, odors, or smoke.
- Do not use an electrical outlet if it is loose or damaged.
- Do not operate or plug in unit with wet hands or in a wet environment.
- Ventilate area before operating dehumidifier. Check for the presence of natural gas or the buildup of other combustible vapors.
- Do not clean the dehumidifier with water. Water may enter the unit and degrade the insulation resulting in an electrical shock.
- If water enters the product, turn off the dehumidifier's power switch, then unplug the unit. Do not plug in unit until it has been inspected by an authorized repair service.
- Because the fan rotates at high speed during operation, always unplug dehumidifier before attempting any recommended maintenance or cleaning.
- Do not block the inlet or outlet. It may cause unit to fail or to operate inefficiently.

- Do not remove plug from outlet by pulling on the cord.
- When not in use, turning the unit off will save energy. Unplug the dehumidifier when not using for long periods of time.
- When removing the filter, be aware that some metal parts may have sharp edges and may cause injury.
- Do not use the water collected in the bucket for drinking purposes. It is not sanitary and could cause illness.
- Do not allow children to play with this product.

Tips

- Make sure the dehumidifier is the correct size for the area you want to dehumidify. It is not designed to dehumidify the entire house.
- For proper operation, the dehumidifier should only be placed on a level floor.
- Close all doors, windows and other openings to the room. The dehumidifier must operate in an enclosed area to be effective.
- To clean, use a soft cloth; do not use wax, thinners, or strong detergents as they may change the color of the unit or cause surface damage.
- Be sure to replace the bucket properly after emptying to prevent water from collecting on the floor causing damage to some types of flooring.
- Do not put a pet or house plant where it will be exposed to direct air flow. This could injure the pet or plant.
- Operation without filter will cause unit failure. Insert the filter securely. Clean it every two weeks. (See Care and Maintenance section in this manual.)

ELECTRICAL REQUIREMENTS

OBSERVE ALL LOCAL CODES AND ORDINANCES.

DO NOT, UNDER ANY CIRCUMSTANCES, REMOVE THE POWER SUPPLY CORD GROUND PRONG.

ELECTRICAL GROUND IS REQUIRED ON THIS APPLIANCE

A 115-VOLT 60Hz, AC ONLY, 15A FUSED AND PROPERLY GROUNDED ELECTRICAL SUPPLY IS REQUIRED.

A time delay fuse or time delay circuit breaker is recommended. Use a dedicated circuit serving only this appliance.

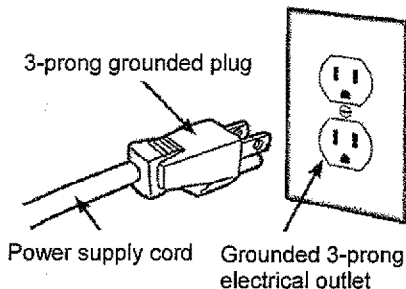

DO NOT USE AN EXTENSION CORD.

RECOMMENDED GROUNDING METHOD

For your personal safety, this appliance must be grounded. This appliance has a power supply cord with a 3-prong grounded plug. To minimize possible shock hazard the cord must be plugged into a matching grounded electrical outlet that complies with the latest edition of the National Electrical Codes and all local codes and ordinances.

If a grounded 3-prong electrical outlet is not available, it is the personal responsibility and obligation of the customer to have one installed by a qualified electrician.



ELECTRICAL SHOCK HAZARD

- Plug into a grounded 3-prong outlet.
- Do not remove the ground pin from the plug
- Do not use an adapter
- Do not use an extension cord.
- Failure to follow these instructions can result in death, fire or electrical shock.

REMOVING CASTERS FROM BUCKET

1. Remove the bucket from the dehumidifier (Fig. 1)

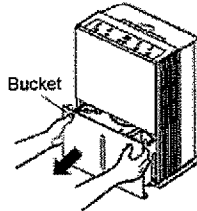

Fig. 1

2. Gently pull at the back and front of the bucket to dislodge the bucket cover from the notches. (Fig. 2)

3. Locate and remove the accessory bag containing the 4 casters (Fig. 3)

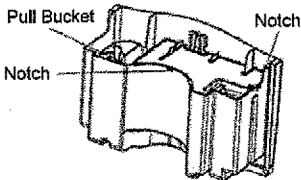

Fig. 2

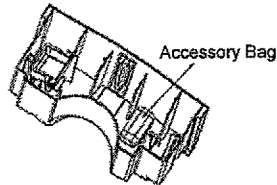

Fig. 3

4. Replace the bucket cover. Make sure the cover is locked into the notches on the bucket and push down (Fig. 4 & 5).

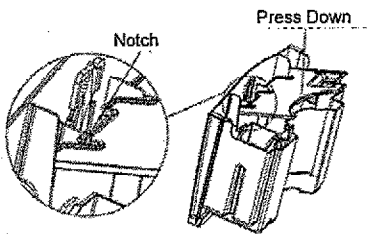

Fig. 4

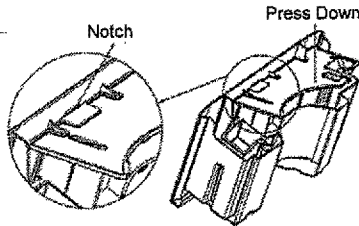

Fig. 5

4. Reinsert the bucket into the dehumidifier (Fig. 6).

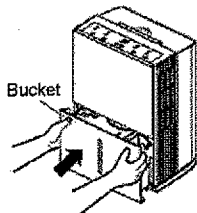
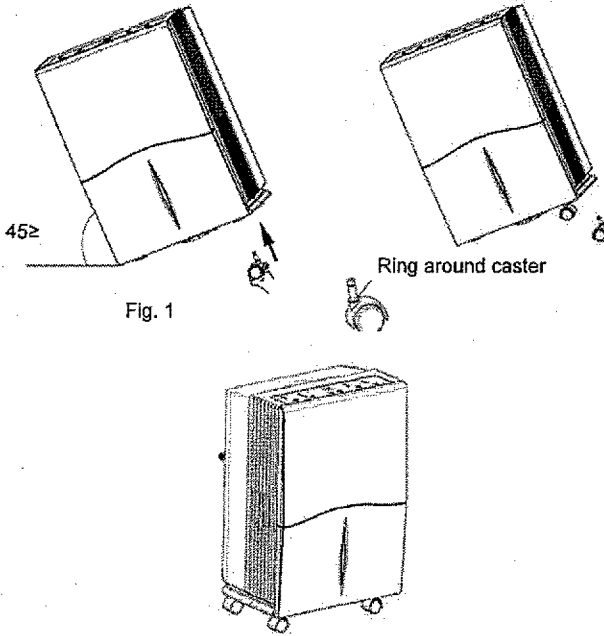

Fig. 6

CASTER INSTALLATION

1. Tilt the dehumidifier no more than 45° and forcibly insert the casters. Make sure the ring around the caster is flush against the bottom of the dehumidifier (Fig. 1)



INSTALLING YOUR DEHUMIDIFIER

- Install the dehumidifier on a level floor strong enough to support the unit with a full bucket of water.
- For best performance, allow at least 12-18 inches of air space on all sides of the unit for good air circulation.
- Keep all outside doors, windows and other openings closed when operating the dehumidifier. Humid outdoor air will add to the unit's workload.
- Leave the dehumidifier in an upright position for 30 minutes before turning on.

DEFROST OPERATION

The dehumidifier has a built-in defrost control that senses frost buildup on the evaporator coils.

During defrosting, the compressor will automatically turn off; the fan will continue running to defrost the coils.

CHOOSING THE PROPER LOCATION

Use the dehumidifier:

- in the basement to help prevent moisture damage.
- in the kitchen, laundry room, bathroom, and spa/exercise areas that have excessive moisture.
- to prevent moisture damage anywhere books or valuables are stored.
- during construction or remodeling to reduce drying time for drywall and paint however check and clean filter often.

AUTOMATIC SHUT OFF

- When the bucket is full, or when the bucket is not in the proper position, the Bucket Full indicator will light up and you will hear a ten second audible alarm. The unit will automatically shut off.
- The bucket must be placed in the proper position for the dehumidifier to work. The Bucket Full light will stay on and the dehumidifier will not run if the bucket is not in the proper position.
- The dehumidifier will shut off once the desired humidity setting is reached plus or minus 5% Relative Humidity (RH).

WARNING

To reduce the risk of fire, electric shock or injury to persons, read the important SAFETY INSTRUCTIONS found on page 3 before operating this appliance.

KEY FEATURES

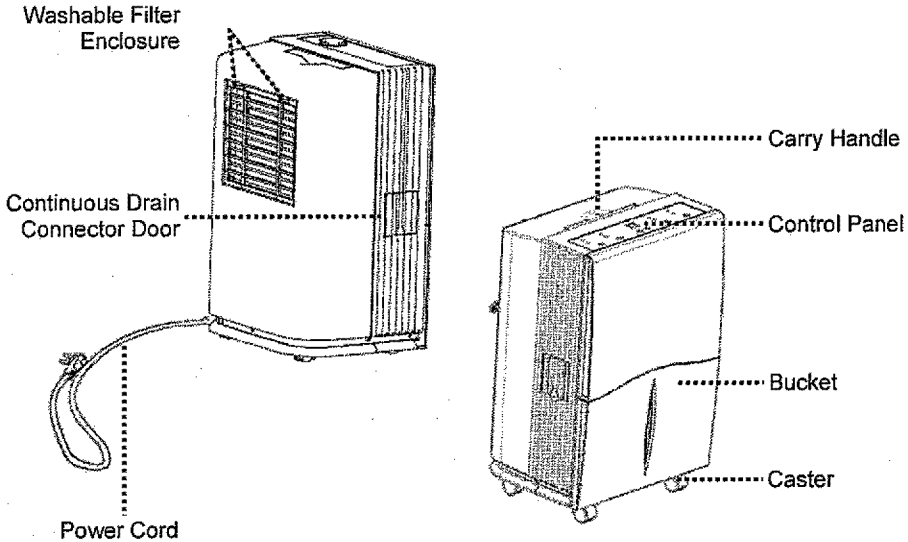

CONTROL PANEL

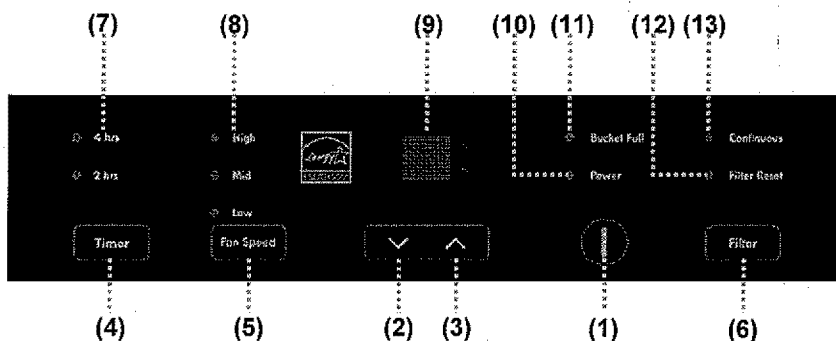

POWER ON/OFF (1)

Once the unit is plugged in, the POWER INDICATOR (10) will light up. Pressing the Power button once will turn the unit ON and illuminate the digital display (9). The display will show the humidity level of the room in 5% increments down to 25%. Pressing the Power button again will turn the display OFF and the unit will cease operating.

HUMIDITY LEVEL (2/3)

The humidity level can be set in 5% increments in a range from 35% to 80%. The humidity setting is shown in the digital display. When the humidity level of the room reaches the set level, the unit will stop dehumidifying.

To set the unit to continuous operation, press the down arrow button until the display shows 35%. Press again and the display will show CO. The Continuous indicator (13) will light up on the control panel. To leave continuous operation, press the up arrow button.

To check the current humidity setting, press the up or down arrow button. The display will show and set 5% above or below the current setting.

FAN SPEED (5)

Press Fan Speed to toggle between Low, Med, and High fan speeds. Speed will be shown in FAN SPEED INDICATOR (8)

BUCKET FULL INDICATOR (11)

When the collection bucket is full, the BUCKET FULL INDICATOR (11) will light up and you will hear an audible alarm. The audible alarm will last up to ten seconds. The dehumidifier will not run until the bucket is removed, emptied and replaced.

DELAY START (4)

Unit can be programmed to turn on at a desired delay time by pressing the Timer (4) key. When the unit is powered OFF, press the timer key once for 2-hour delay start. The 2 Hrs (7) timer indicator will light up when the timer key is pressed. Press the timer key once more for a 4-hour delay start. The 4 Hrs (7) timer indicator will now light up. Press the timer key a third time to clear the timer setting. No timer indicators will light up when the timer setting is cleared.

AUTO SHUT-OFF (4)

Unit can be programmed to turn off at a desired time by pressing the Timer (4) key. When the unit is powered ON, press the timer key once for 2-hour automatic shut-off. The 2 Hrs (7) timer indicator will light up when the timer key is pressed. Press the timer key once more for a 4-hour automatic shut-off. The 4 Hrs (7) timer indicator will now light up. Press the timer key a third time to clear the timer setting. No timer indicators will light up when the timer setting is cleared.

FILTER RESET (12)

The FILTER RESET indicator (12) will light up when the filter needs cleaning. Remove the filter and clean accordingly. Replace the filter when finished and press and hold the FILTER (6) key up to 5 seconds to reset the filter indicator.

WATER DISPOSING OPTIONS

OPTION 1: EMPTYING MANUALLY

1. Pull out the bucket, grasping the side handles. (Fig. 1)
2. Carry the bucket by grasping the front corner of the bucket with one hand and the back of the bucket with the other hand (Fig. 2)
3. Empty the bucket and replace the bucket in the dehumidifier. (Fig. 3)

NOTE: Dehumidifier will not work when the BUCKET FULL indicator light is on or without the bucket properly placed in position.

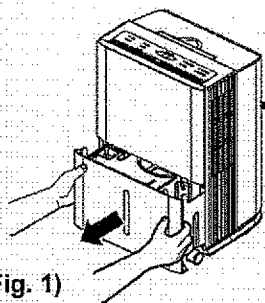

(Fig. 1)

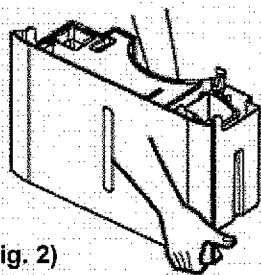

(Fig. 2)

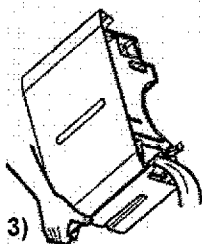

(Fig. 3)

OPTION 2: GRAVITY DRAIN HOSE (Hose Not Provided)

1. Remove the BUCKET from the unit. (Fig. 4)
2. Open the drain connector door (Fig. 5)
3. Thread a garden hose (sold separately) onto the DRAIN CONNECTOR NOZZLE located inside the drain connector door. (Fig. 5)
4. Place the bucket in the dehumidifier for operation. (Fig. 6)

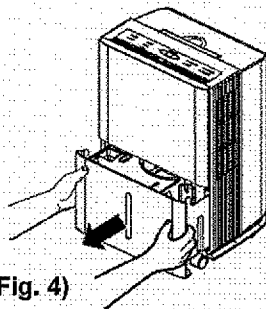

(Fig. 4)

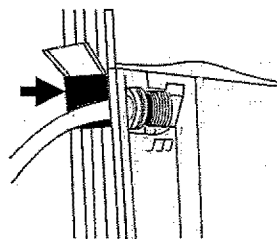

(Fig. 5)

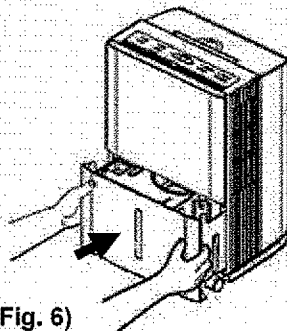

(Fig. 6)

CARE AND MAINTENANCE

CLEANING THE AIR FILTER

After 250 hours of operation the **FILTER RESET** indicator will light up to remind you to clean and change the air filter.

It is recommended to periodically check the filter for excess dirt even if the **FILTER RESET** indicator is off.

1. To remove the air filter, press the two filter tabs and pull the filter holder away from the back of the unit.
2. Remove the filter and clean with warm, soapy water. Rinse and allow the filter to dry before placing back in the unit.
3. Place the filter back into dehumidifier. Plug unit back into outlet, power the unit on and press and hold the **FILTER** key up to 5 seconds on the control panel to reset the filter setting.

NOTE: DO NOT place the filter in a dishwasher

CAUTION: DO NOT operate the dehumidifier without a filter. Doing so may cause a unit failure.



WARNING

- Disconnect power supply cord from receptacle before performing any maintenance.

CLEANING THE EXTERIOR

Clean the cabinet using a damp cloth and a mild detergent. Do not use bleach or abrasives.

CONTROL PANEL

Wipe down the control panel with a dry cloth.

CLEANING THE BUCKET

Every few weeks, clean the dehumidifier bucket. Partially fill the bucket with clean water and mild detergent. Swish the mixture around in the bucket, empty and rinse. Replace the bucket when finished

NOTE: Do not place the bucket in a dishwasher.

FILTER TABS

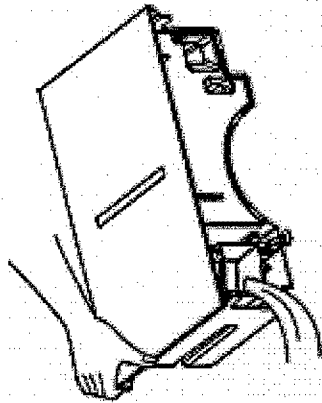
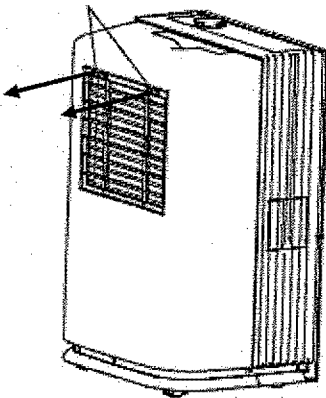

TROUBLESHOOTING

| Problem | Possible Causes | Solutions |
|--|---|---|
| Dehumidifier does not start. | The dehumidifier is unplugged. | Make sure the dehumidifier's plug is pushed completely into the outlet. |
| | The fuse is blown / circuit breaker is tripped. | Check the house fuse / circuit breaker box and replace fuse or reset breaker. |
| | Dehumidifier has reached the user set humidity level or the bucket is full. | The dehumidifier automatically turns off when either condition occurs. Change to a lower setting or empty the water bucket and replace properly. |
| | Bucket is not in the proper position. | The bucket must be in place and securely seated for the dehumidifier to operate. |
| | Power Failure. | There is a protective time delay (up to 3 min.) to prevent tripping of the compressor overload. For this reason, the unit may not start normal dehumidification for 3 min. after it is powered back on. |
| Dehumidifier is not operating as Intended. | Not enough time allowed for unit to remove moisture. | When first installed, allow at least 24 hours to achieve the desired humidity level. |
| | Airflow is restricted. | Make sure there are no curtains, blinds, or furniture blocking the side or back of the dehumidifier. |
| | Dirty filter. | See the Cleaning The Air Filter section |
| | The user set Humidity Level may not be set low enough. | To reduce moisture, press the down arrow button to lower the percent humidity desired in the room, or set the dehumidifier to CO for continuous operation. |
| | Doors and windows may not be closed tightly. | Check that all doors, windows, and other openings are securely closed. |
| | Water is not draining through drain hose | Make sure the drain is placed below the drain connector nozzle to allow gravity to drain the water (Refer to Gravity Drain Hose section in this manual). |
| | Room temperature is too low. | Moisture removal is best at higher room temperatures. Lower room temperatures will reduce the moisture removal rate. This model is designed to operate at temperatures above 41°F. |
| Filter Indicator is lit. | Filter needs to be cleaned every 250 hours of use. | Once filter has been cleaned, press the FILTER button for 3 seconds to turn the filter indicator off. |

TROUBLESHOOTING

| | | |
|---------------------------------------|---|---|
| Dehumidifier runs too much | The area to be dehumidified is too large. | The capacity of your dehumidifier may not be adequate for the room size. |
| | Doors and windows are open. | Close all doors and windows to the outside. |
| Frost appears on the coils | The dehumidifier has recently been turned on or the room temperature is below 41°F. | This is normal. Frost will usually disappear within 60 minutes. |
| The controls cannot be set or changed | The compressor turns off and the fan continues to run for approximately 3 minutes at a fixed setting. | This is normal. Wait approximately 3 minutes until this automatic process finishes, then the fan control can be set to the desired level. |
| Fan Noise | Air is moving through the unit. | This is normal. |
| Water on the floor | Hose connection may be loose. | Check the hose connection. See the Drainage Section. |
| | Hose is attached but not draining into a drain. | Check hose for obstruction. |

ERROR CODES

| Error Code | Error Type | Possible Cause | Corrective Action |
|------------|---|--|---|
| F1 | Ambient Temperature Sensor Malfunction | 1. Sudden Change in the surrounding temperature. | 1. Unplug the dehumidifier. 2. Check the surrounding area for possible reasons for sudden temperature changes. 3. Wait 30 minutes before plugging the dehumidifier back in for normal operation. 4. If the "Error" is still indicated, please contact your nearest service center. Call 1-800-488-1222 for service center locations. |
| F2 | Evaporative Coil Temperature Sensor Malfunction | 2. Faulty Sensor | |

PRODUCT SPECIFICATIONS

| ITEM # | 52301 |
|---------------------------------|---|
| Moisture Removal per 24 hours | 30 Pints per day (14.2 Liters per day) |
| Power Consumption (W) | 410 Watts |
| Bucket Capacity | 8.5 Pints (4 Liters) |
| Power Source | 115 V / 60 HZ |
| Rated Current (Amps) | 3.7A |
| Sound Pressure Level dB (L/M/H) | 45/47/49 dB(A) |
| Weight | 36.3 lbs kg |
| Dimensions (W x D x H) | 13.5" x 10.3" x 19.3" (343x262x490 mm) |
| Energy Star | Yes |

Master Protection Agreements

Congratulations on making a smart purchase. Your new Kenmore® product is designed and manufactured for years of dependable operation. But like all products, it may require preventive maintenance or repair from time to time. That's when having a Master Protection Agreement can save you money and aggravation. The Master Protection Agreement also helps extend the life of your new product. Here's what the Agreement* includes:

- ☑ **Parts and labor** not just for repairing defects, but to help keep products operating properly **under normal use**. Our coverage goes **well beyond the product warranty**. No deductibles, no functional failure excluded from coverage—**real protection**.
- ☑ **Expert service** by a force of more than **10,000 authorized Sears service technicians**, which means someone you can trust will be working on your product.
- ☑ **Unlimited service calls and nationwide service**, as often as you want us, whenever you want us.
- ☑ **"No-lemon" guarantee** – replacement of your covered product if four or more product failures occur within twelve months.
- ☑ **Product replacement** if your covered product can't be fixed.
- ☑ **Annual Preventive Maintenance Check** at your request – no extra charge.
- ☑ **Fast help by phone** – we call it **Rapid Resolution** – phone support from a Sears representative on all products. Think of us as a "talking owner's manual."
- ☑ **Power surge protection** against electrical damage due to power fluctuations.
- ☑ **\$250 Food Loss Protection** annually for any food spoilage that is the result of mechanical failure of any covered refrigerator or freezer.
- ☑ **Rental reimbursement** if repair of your covered product takes longer than promised.
- ☑ **10% discount** off the regular price of any non-covered repair service and related installed parts.

Once you purchase the Agreement, a simple phone call is all that it takes for you to schedule service. You can call anytime day or night, or schedule a service appointment online.

The Master Protection Agreement is a risk free purchase. If you cancel for any reason during the product warranty period, we will provide a full refund. Or, a prorated refund anytime after the product warranty period expires. Purchase your Master Protection Agreement today!

Some limitations and exclusions apply. For prices and additional information in the U.S.A. call 1-800-827-6655.

*** Coverage in Canada varies on some items. For full details call Sears Canada at 1-800-361-6665.**

Sears Installation Service

For Sears professional installation of home appliances, garage door openers, water heaters, and other major home items, in the U.S.A. or Canada call **1-800-4-MY-HOME®**.

SPANISH SECTION

Get it fixed, at your home or ours!

Your Home

For troubleshooting, product manuals and expert advice:



www.managemylife.com

For repair – in your home – of all major brand appliances, lawn and garden equipment, or heating and cooling systems, no matter who made it, no matter who sold it!

For the replacement parts, accessories and owner's manuals that you need to do-it-yourself.

For Sears professional installation of home appliances and items like garage door openers and water heaters.

1-800-4-MY-HOME® (1-800-469-4663)

Call anytime, day or night

www.sears.com

Our Home

For repair of carry-in items like vacuums, lawn equipment, and electronics, call anytime for the location of your nearest

Sears Parts & Repair Service Center

1-800-488-1222 (U.S.A.)

www.sears.com

To purchase a protection agreement on a product serviced by Sears:

1-800-827-6655 (U.S.A.)

Para pedir servicio de reparación a domicilio, y para ordenar piezas:

1-888-SU-HOGAR®

(1-888-784-6427)

www.sears.com

sears

© Registered Trademark / ™ Trademark of KCD IP, LLC in the United States, or Sears Brands, LLC in other countries
© Marca Registrada / ™ Marca de Fábrica de KCD IP, LLC en Estados Unidos, o Sears Brands, LLC in otros países